



**the
t.bone**

freeU HT, freeU PT
UHF wireless system

Thomann GmbH

Hans-Thomann-Straße 1

96138 Burgebrach

Germany

Telephone: +49 (0) 9546 9223-0

Internet: www.thomann.de

25.01.2022, ID: 405079, 405080, 405081, 405082, 405083, 405084 (V7)

Table of contents

1	General information	5
1.1	Further information.....	6
1.2	Notational conventions.....	7
1.3	Symbols and signal words.....	9
2	Safety instructions	10
3	Features	13
4	Installation and starting up	18
4.1	General Information.....	18
4.2	Receiver.....	19
4.3	Handheld microphone.....	21
4.4	Bodypack transmitter.....	22
5	Connections and controls	23
5.1	Receiver.....	23
5.2	Handheld microphone.....	30
5.3	Bodypack transmitter.....	33

6	Operating.....	36
6.1	Receiver.....	36
6.2	Handheld microphone.....	40
6.3	Bodypack transmitter.....	41
7	Technical specifications.....	44
7.1	Receiver.....	44
7.2	Handheld microphone.....	47
7.3	Bodypack transmitter.....	50
8	Plug and connection assignment.....	53
9	Troubleshooting.....	56
10	Protecting the environment.....	59

1 General information

This user manual contains important information on the safe operation of the device. Read and follow all safety notes and all instructions. Save this manual for future reference. Make sure that it is available to all persons using this device. If you sell the device to another user, be sure that they also receive this manual.

Our products and user manuals are subject to a process of continuous development. We therefore reserve the right to make changes without notice. Please refer to the latest version of the user manual which is ready for download under www.thomann.de.

1.1 Further information

On our website (www.thomann.de) you will find lots of further information and details on the following points:

Download	This manual is also available as PDF file for you to download.
Keyword search	Use the search function in the electronic version to find the topics of interest for you quickly.
Online guides	Our online guides provide detailed information on technical basics and terms.
Personal consultation	For personal consultation please contact our technical hotline.
Service	If you have any problems with the device the customer service will gladly assist you.

1.2 Notational conventions

This manual uses the following notational conventions:

Letterings

The letterings for connectors and controls are marked by square brackets and italics.

Examples: *[VOLUME]* control, *[Mono]* button.

Displays

Texts and values displayed on the device are marked by quotation marks and italics.

Examples: *'24ch'*, *'OFF'*.

Instructions

The individual steps of an instruction are numbered consecutively. The result of a step is indented and highlighted by an arrow.

Example:

1. ▶ Switch on the device.
2. ▶ Press *[Auto]*.
 - ⇒ Automatic operation is started.
3. ▶ Switch off the device.

Cross-references

References to other locations in this manual are identified by an arrow and the specified page number. In the electronic version of the manual, you can click the cross-reference to jump to the specified location.

Example: See ↗ *'Cross-references' on page 8.*

1.3 Symbols and signal words

In this section you will find an overview of the meaning of symbols and signal words that are used in this manual.

Signal word	Meaning
DANGER!	This combination of symbol and signal word indicates an immediate dangerous situation that will result in death or serious injury if it is not avoided.
NOTICE!	This combination of symbol and signal word indicates a possible dangerous situation that can result in material and environmental damage if it is not avoided.
Warning signs	Type of danger
	Warning – danger zone.

2 Safety instructions

Intended use

This device is intended to be used for the wireless transmission of audio signals from microphones or instruments to amplifiers or active speakers. Use the device only as described in this user manual. Any other use or use under other operating conditions is considered to be improper and may result in personal injury or property damage. No liability will be assumed for damages resulting from improper use.

This device may be used only by persons with sufficient physical, sensorial, and intellectual abilities and having corresponding knowledge and experience. Other persons may use this device only if they are supervised or instructed by a person who is responsible for their safety.

Safety



DANGER!

Danger for children

Ensure that plastic bags, packaging, etc. are disposed of properly and are not within reach of babies and young children. Choking hazard! Ensure that children do not detach any small parts (e.g. knobs or the like) from the unit. They could swallow the pieces and choke! Never let children unattended use electrical devices.



NOTICE!

Operating conditions



This device has been designed for indoor use only. To prevent damage, never expose the device to any liquid or moisture. Avoid direct sunlight, heavy dirt, and strong vibrations. Only operate the device within the ambient conditions specified in the chapter 'Technical specifications' of this user manual. Avoid heavy temperature fluctuations and do not switch the device on immediately after it was exposed to temperature fluctuations (for example after transport at low outside temperatures). Dust and dirt inside can damage the unit. When operated in harmful ambient conditions (dust, smoke, nicotine, fog, etc.), the unit should be maintained by qualified service personnel at regular intervals to prevent overheating and other malfunction.



NOTICE!

External power supply



The device is powered by an external power supply. Before connecting the external power supply, ensure that the input voltage (AC outlet) matches the voltage rating of the device and that the AC outlet is protected by a residual current circuit breaker. Failure to do so could result in damage to the device and possibly the user. Unplug the external power supply before electrical storms occur and when the device is unused for long periods of time to reduce the risk of electric shock or fire.



NOTICE!

Radio interference



This device emits electromagnetic signals. This can cause interference due to overlapping radio waves. Do not use the device in locations where the use of wireless devices is prohibited.



NOTICE!

Risk of fire due to incorrect polarity



Incorrectly inserted batteries may destroy the device or the batteries. Ensure that proper polarity is observed when inserting batteries.



NOTICE!

Possible damage by leaking batteries



Leaking batteries can cause permanent damage to the device. Take batteries out of the device if it is not going to be used for a longer period.



NOTICE!

Possible staining



The plasticiser contained in the rubber feet of this product may possibly react with the coating of your surface and after some time cause permanent dark stains. In case of doubt, do not put the rubber feet directly on the surface and use a suitable underlay if necessary, i.e. felt-pad floor protectors or similar.

3 Features

The UHF wireless system is particularly suitable for professional audio transmission, for example, at events, on rock stages and in concert halls, theatres, musicals or night clubs.

UHF Wireless System freeU HT

Item no.	Name	Frequency band
405081	the t.bone freeU HT 600	606 MHz...630 MHz
405079	the t.bone freeU HT 823	823 MHz...832 MHz
405083	the t.bone freeU HT 863	863 MHz...865 MHz

The UHF Wireless System freeU HT is comprised of the following components:

- 9.5" Diversity receiver
 - Two antennas for optimum reception quality
 - Infrared interface for sending the frequency selection from the receiver to the transmitter
 - Outputs: XLR, 1/4" jack socket
 - solid metal housing, 9.5" rack mountable (1 RU)
 - Power supply: 12 V $\overline{\text{DC}}$
- Transmitter
 - battery powered handheld super cardioid microphone
- Accessories included
 - Two antennas
 - Power adapter
 - Installation kit for the rack mounting
 - Microphone holder

The system operates with pre-programmed frequency groups. The following table shows the number of available pre-programmed groups and the number of pre-programmed frequencies in each group.

Item no.	Name	Pre-programmed frequency groups	Available channels per group
405081	the t.bone freeU HT 600	10	10
405079	the t.bone freeU HT 823	10	10
405083	the t.bone freeU HT 863	4	4

UHF Wireless System freeU PT

Item no.	Name	Frequency band
405082	the t.bone freeU PT 600	606 MHz...630 MHz
405080	the t.bone freeU PT 823	823 MHz...832 MHz
405084	the t.bone freeU PT 863	863 MHz...865 MHz

The UHF Wireless System freeU PT is comprised of the following components:

- 9.5" Diversity receiver
 - Two antennas for optimum reception quality
 - Infrared interface for sending the frequency selection from the receiver to the transmitter
 - Outputs: XLR, 1/4" jack socket
 - solid metal housing, 9.5" rack mountable (1 RU)
 - Power supply: 12 V $\overline{=}$
- Transmitter
 - battery powered bodypack transmitter
- Accessories included
 - Two antennas
 - Power adapter
 - Installation kit for the rack mounting
 - Instrument cable

The system operates with pre-programmed frequency groups. The following table shows the number of available pre-programmed groups and the number of pre-programmed frequencies in each group.

Item no.	Name	Pre-programmed frequency groups	Available channels per group
405082	the t.bone freeU PT 600	10	10
405080	the t.bone freeU PT 823	10	10
405084	the t.bone freeU PT 863	4	4

4 Installation and starting up

4.1 General Information

Unpack and check carefully there is no transportation damage before using the unit. Keep the equipment packaging. To fully protect the product against vibration, dust and moisture during transportation or storage use the original packaging or your own packaging material suitable for transport or storage, respectively.

Create all connections while the device is off. Use the shortest possible high-quality cables for all connections. Take care when running the cables to prevent tripping hazards.

Notes on wireless transmission

- This device utilizes frequencies that are not harmonized within the European Union (EU) and therefore may only be used in certain EU member states. In all European countries, the frequencies used for the transmission of audio signals are strictly regulated. Before you start, make sure the frequencies are allowed in the respective country and check whether the operation must be reported to the appropriate authority. For more information, please visit: <http://www.thomann.de>.
- Make sure that transmitter and receiver are both tuned to the same channel.
- Never set multiple transmitters to the same channel.
- Make sure that there are no metal objects between the transmitter and receiver.
- Avoid interference from other radio or in-ear systems.

4.2 Receiver

Rack mounting

The unit has been designed for rack mounting in a standard 9.5" rack; it occupies one rack unit (RU). The included rack angles have been designed for the mounting of a receiver in a 19" rack. It occupies one rack unit.

Connect the power supply



NOTICE!

External power supply

The device is powered by an external power supply. Before connecting the external power supply, ensure that the input voltage (AC outlet) matches the voltage rating of the device and that the AC outlet is protected by a residual current circuit breaker. Failure to do so could result in damage to the device and possibly the user.

Unplug the external power supply before electrical storms occur and when the device is unused for long periods of time to reduce the risk of electric shock or fire.

First, connect the power adapter to the receiver and then plug the power adapter into the power outlet.

Attaching the antennas

Attach the included antennas to the rear panel of the transmitter. To improve the transmission quality and to adapt to the spatial conditions they are rotatable and swivelling.

In case the space provided on the device for direct assembly of the antennas is not sufficient, for example because the space on the rack is narrow, you can use the optionally available coaxial cable to assemble the antennas separately from the device.

Connecting audio and starting up

Connect one of the audio outputs of the receiver to your mixer or your amplifier. Ensure that only one of the two outputs is ever used at a time, because faults might occur otherwise.

4.3 Handheld microphone

Inserting batteries

Unscrew the bottom housing section of the handheld microphone. Insert the batteries. Pay attention to the correct location of the poles. The correct battery arrangement is illustrated in the battery compartment. Close the battery compartment, screw the bottom housing section back on, and switch the transmitter on.



Make sure that you screw open the complete lower housing part. Do not screw open the threaded ring above the antenna.

4.4 Bodypack transmitter

Inserting batteries

Squeeze the battery compartment lid, flip it open and insert the batteries. Pay attention to the correct location of the poles. Close the battery compartment and switch the transmitter on.

Connecting microphone of instrument

- Ensure that the transmitter is switched off.
- Connect the microphone or instrument cable to the input on the transmitter (mini-XLR panel connector).
- Turn on the transmitter and check the transmission by using the microphone or instrument. If necessary, adjust the amplification of the transmitter and the levels on your mixing console or your amplifier.

5 Connections and controls

5.1 Receiver

Front panel

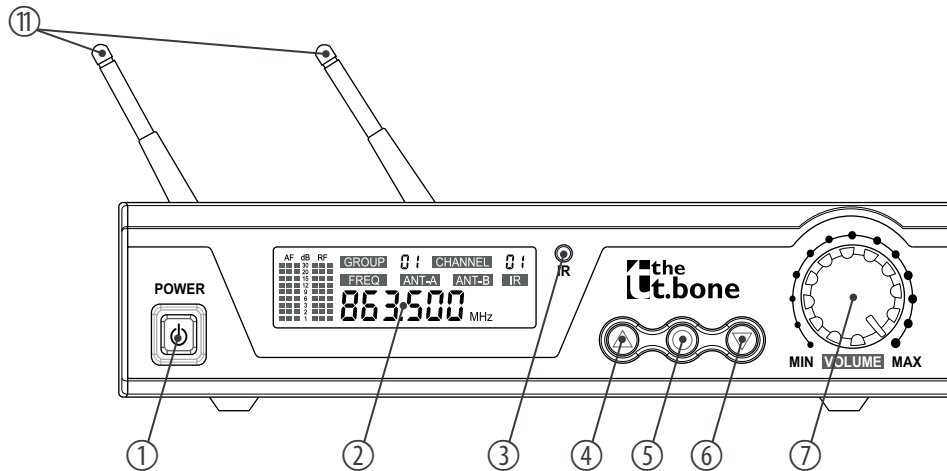

freeU HT, freeU PT

1	<i>[POWER]</i> Press the switch to switch the device on or off. All previous settings are retained even when you switch the device off and disconnect it from the mains.
2	Display
3	<i>[IR]</i> Infrared sensor
4	▲ Increases the displayed value by one.
5	<i>[SET]</i> Opens the menu.
6	▼ Decreases the displayed value by one.

7	<i>[VOLUME]</i> Volume control to adjust the audio output level.
---	---

11	UHF antennas.
----	---------------

Rear panel

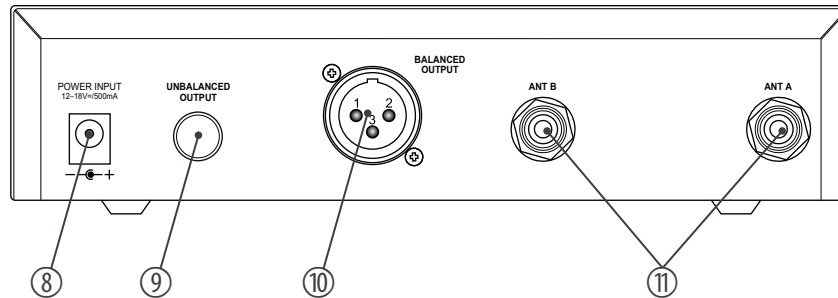

8 [DC INPUT 12-18V]

Socket for connecting the supplied AC power supply. If you are using a different power supply, observe the correct voltage, the polarity of the plug and the power consumption.

9 [UNBALANCED OUTPUT]

1/4" phone socket as unbalanced audio signal output for direct connection to a mixer, a power amp or recording device.

- | | |
|----|---|
| 10 | <i>[BALANCED OUTPUT]</i>
XLR panel plug as balanced audio signal output for direct connection to a mixer, a power amp or recording device. |
| 11 | <i>[ANT A], [ANT B]</i>
UHF antenna connections. |

Display

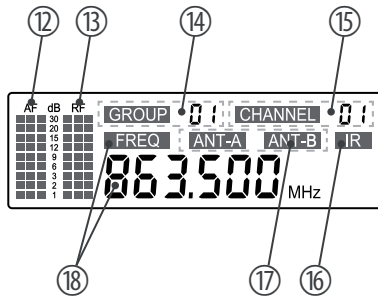

- | | | |
|----|-----------|---|
| 12 | [AF] | Level display for the audio signal. |
| 13 | [RF] | Level indicator for the received radio signal. |
| 14 | [GROUP] | Indicates the selected frequency group. |
| 15 | [CHANNEL] | Indicates the selected channel. |
| 16 | [IR] | Indicates data transfer via infrared interface. |

17 *[ANT-A], [ANT-B]*

Shows which of the two antennas is currently being used for signal transmission.

18 *[FREQ]*

Indicates the frequency that is assigned to the set combination of frequency group and channel.

5.2 Handheld microphone

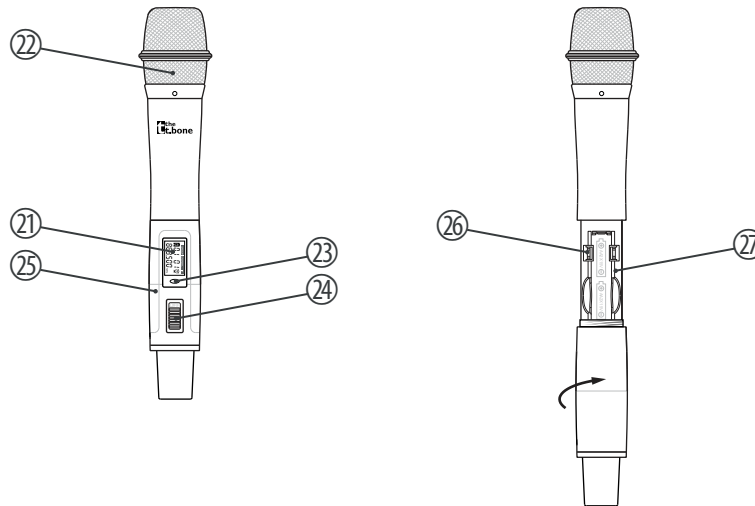

21	Display
22	Microphone head grill to prevent damage and to reduce wind and breath noise.
23	Infrared sensor
24	<p>Main switch</p> <p>Slide the switch all the way forward to turn on the microphone. Slide it all the way back to turn it off. Set the switch to the centre position to mute the microphone.</p>
25	<p>Lower housing part. Unscrew to open.</p> <p>Make sure that you screw open the complete lower housing part.</p> <p>Caution! Do not screw open the threaded ring (left-hand thread) above the antenna.</p>
26	Indicating the frequency range in which the device operates. The specification here must match the specification printed on the back of the receiver.
27	Battery holder for two round cell batteries (AA, LR06), 1.5 V or comparable rechargeable batteries.

Display

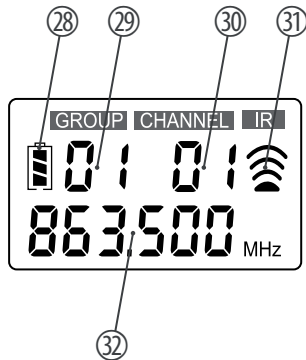

28	Battery level indicator. Replace the batteries when only one blinking bar remains displayed. Reduces the voltage of the batteries even further if the transmitter is automatically switched off.
29	<i>[GROUP]</i> Indicates the selected frequency group.
30	<i>[CHANNEL]</i> Indicates the selected channel.
31	<i>[IR]</i> Indicates data transfer via infrared interface.
32	Indicates the set frequency that is assigned to the set combination of frequency group and channel.

5.3 Bodypack transmitter

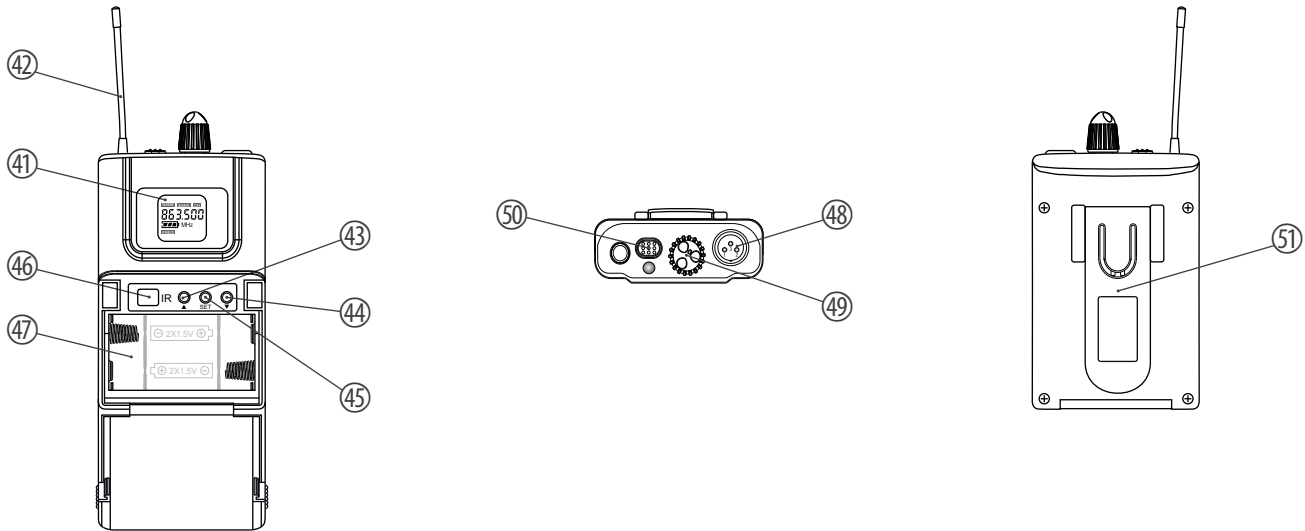

freeU HT, freeU PT

41	Display
42	Antenna
43	▲ Increases the displayed value by one.
44	● Opens the menu.
45	▼ Decreases the displayed value by one.
46	[IR] Infrared sensor
47	Battery holder for two round cell batteries (AA, LR06), 1.5 V or comparable rechargeable batteries.
48	Mini-XLR chassis plug for connecting a microphone or instrument.
49	Volume control

50	Main switch Press the switch for several seconds to switch the device on or off.
51	Retaining clamp

Display

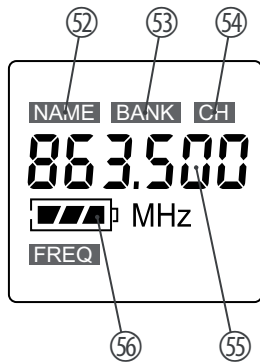

52, 53, 54	[NAME], [BANK], [CH] No function.
55	[FREQ] Indicates the set frequency that is assigned to the set combination of frequency group and channel.
56	Battery level indicator. Replace the batteries when only one blinking bar remains displayed. Reduces the voltage of the batteries even further if the transmitter is automatically switched off.

6 Operating

6.1 Receiver

Turning the receiver on / off

- Turn on the power using the main switch.
- ⇒ The display is activated. The device is operational. Now, you can make the desired settings.

Selecting frequency group and channel

1. ▶ Press ●.
⇒ The *[GROUP]* display blinks.
2. ▶ Use the arrow keys to select the frequency group.
3. ▶ Press ● to confirm the selection.
⇒ The selected setting is accepted. The *[CHANNEL]* display blinks.
4. ▶ Use the arrow keys to select a channel within the set frequency group.
5. ▶ Press ● to confirm the selection.
⇒ The selected setting is accepted. The *[PO.x]* display blinks.
6. ▶ Use the arrow buttons to select the level for the radio signal in a range from 5 mW (PO.1) to 30 mW (PO.4) (this option is omitted for the t.bone freeU HT 863 and the t.bone freeU PT 863).

Press ● to confirm the selection.
⇒ The settings are complete.

Check the frequency

- Press ● on the receiver repeatedly until the display shows 'SCAN'.
- ⇒ The 'SCAN' display blinks. The device checks the set combination of frequency group and channel on possible interferences.
If the set channel is free, the display shows the frequency with the status message 'PF'.
If the set channel is not free, the display shows the frequency without the status message 'PF'. In this case search for a free channel.

Searching for a free channel

1. ➤ Press ● on the receiver repeatedly until the display shows 'SCAN'.
 - ⇒ The 'SCAN' display blinks.
2. ➤ Press the arrow keys while 'SCAN' is blinking.
 - ⇒ The device searches automatically for a free channel. If a free channel has been found, the display shows the frequency with the status message 'PF'.

Synchronising the receiver with the transmitter

1. ➤ Press and hold ● on the receiver until the display shows 'F---'.
⇒ The 'IR' display blinks.
2. ➤ Hold the infrared sensor of the transmitter near the infrared interface of the receiver.
⇒ The settings of the receiver are transmitted to the transmitter.
3. ➤ Once the synchronisation is finished, the display returns to the default state and 'IR' lights permanently.

Performing a hardware reset

1. ➤ Disconnect the power adapter of the receiver from the power supply.
2. ➤ Hold [POWER] down and reconnect simultaneously the power adapter of the receiver to the power supply.

6.2 Handheld microphone

Turning the microphone on / off

1. ➤ Slide the switch all the way forward (ON) to turn on the microphone.
2. ➤ Slide the switch all the way back (OFF) to turn it off.
3. ➤ Set the switch to the centre position to mute the microphone.

Synchronising the receiver with the microphone

1. ➤ Prepare the receiver for the synchronisation (↻ *'Synchronising the receiver with the transmitter' on page 39*).
2. ➤ Hold the infrared sensor of the microphone near the infrared interface of the receiver.
⇒ The settings of the receiver are transmitted to the microphone and are displayed.

6.3 Bodypack transmitter

Turn the bodypack transmitter on / off

1. ➤ Briefly press the main switch on the top of the unit to turn the bodypack transmitter on.
 - ⇒ The display shows the frequency and the charging level of the batteries. The device is operational.
2. ➤ Hold down the main switch on the top of the unit to turn the bodypack transmitter off.
 - ⇒ The display shows 'OFF' for a few seconds. Then the display turns black. The unit is turned off.

Synchronising the bodypack transmitter with the receiver

1. ▶ Prepare the receiver for the synchronisation (↪ 'Synchronising the receiver with the transmitter' on page 39).
2. ▶ Press the lid of the battery compartment of the bodypack transmitter on one side and flip the lid open. The infrared sensor [IR] of the unit is located above the batteries.
3. ▶ Hold the infrared sensor of the bodypack transmitter near the infrared interface of the receiver.
 - ⇒ The settings of the receiver are transmitted to the bodypack transmitter and are displayed.

Setting the frequency manually

If you don't want to synchronise the transmitter with the receiver using the infrared interface, you can also set the transmission frequency manually.

1. ▶ Press the lid of the battery compartment of the bodypack transmitter on one side and flip the lid open. The buttons for operating the unit are located above the batteries.



The buttons for operating the unit are located in a recess. Use a ballpen or another suitable sharp tool to press the buttons.

2. ▶ Press **[SET]** until the numeric value flashes in the display.
3. ▶ Use the arrow buttons to select the desired frequency.
Press **[SET]** to confirm the selection.
⇒ The selected transmission frequency is set.

7 Technical specifications

7.1 Receiver

Input connections	Power supply	Socket for connecting the power adapter
Output connections	Audio signal output	1× 1/4" jack socket (unbalanced)
	Audio signal output	1 ×XLR panel plug, balanced
Output level adjustment	-32 dB ... +0 dB	
Frequency range	50 Hz...16 kHz (±3 dB)	
Antenna gain	2 dBi	
Total harmonic distortion (THD)	< 0,5 % (1 kHz)	
Signal-to-noise ratio	> 105 dB (A) (-60 dBm)	
Dynamic range	> 100 dB	
Power supply	External power adapter, 100 - 240 V ~ 50/60 Hz	

Operating voltage	12 V $\overline{\text{---}}$ / 500 mA, centre positive	
Dimensions (W × H × D, without antennas)	210 mm × 44 mm × 170 mm	
Weight	865 g	
Ambient conditions	Temperature range	0 °C...40 °C
	Relative humidity	20 %...80 % (non-condensing)

Carrier frequency, frequency band, number of channels, bandwidth, switching bandwidth and modulation type correspond to those of the transmitter.

Further information

Frequency band	UHF
Diversity	Yes
Switchable frequencies	Yes
Detachable antennas	Yes
Pilot tone	Yes

7.2 Handheld microphone

	the t.bone freeU HT 600 (item no. 405081)	the t.bone freeU HT 823 (item no. 405079)	the t.bone freeU HT 863 (item no. 405083)
Carrier frequency	UHF band (600 MHz...952 MHz)		
Frequency range	606 MHz...630 MHz	823 MHz...832 MHz	863 MHz...865 MHz
Max. transmission power	Adjustable in four levels: PO.1: 5 mW PO.2: 10 mW PO.3: 15 mW PO.4: 30 mW	Adjustable in four levels: PO.1: 5 mW PO.2: 10 mW PO.3: 15 mW PO.4: 30 mW	10 mW
Maximum input level	-12 dBV		
Bandwidth	24 MHz	9 MHz	2 MHz
Input impedance	5.6 kΩ		
Range in clear field of vision	up to 70 m		

	the t.bone freeU HT 600 (item no. 405081)	the t.bone freeU HT 823 (item no. 405079)	the t.bone freeU HT 863 (item no. 405083)
Number of channels	100 (10 pre-programmed frequency groups, each with 10 channels available)	100 (10 pre-programmed frequency groups, each with 10 channels available)	16 (4 pre-programmed frequency groups, each with 4 channels available)
Max. number of parallel systems	6-8	3-4	3
Modulation type	Frequency modulation (FM)		
Frequency range	50 Hz... 16 kHz (± 3 dB)		
Spurious response rejection ratio	> 55 dBc		
Peak deviation	± 48 kHz		
Power supply	2 \times AA cells (LR06, 1.5 V) or corresponding rechargeable batteries		
Operating time	> 10 h (with alkaline cells)		
Dimensions (L \times D)	265 mm \times 65 mm		
Weight (without batteries)	370 g		

		the t.bone freeU HT 600 (item no. 405081)	the t.bone freeU HT 823 (item no. 405079)	the t.bone freeU HT 863 (item no. 405083)
Ambient conditions	Temperature range	0 °C...40 °C		
	Relative humidity	20 %...80 % (non-condensing)		

Further information

Capsule type	Dynamic
--------------	---------

7.3 Bodypack transmitter

	the t.bone freeU PT 600 (item no. 405082)	the t.bone freeU PT 823 (item no. 405080)	the t.bone freeU PT 863 (item no. 405084)
Carrier frequency	UHF band (600 MHz...952 MHz)		
Frequency range	606 MHz...630 MHz	823 MHz...832 MHz	863 MHz...865 MHz
Max. transmission power	Adjustable in four levels: PO.1: 5 mW PO.2: 10 mW PO.3: 15 mW PO.4: 30 mW	Adjustable in four levels: PO.1: 5 mW PO.2: 10 mW PO.3: 15 mW PO.4: 30 mW	10 mW
Bandwidth	24 MHz	9 MHz	2 MHz
Maximum input level	-4.15 dBV		
Input impedance	6.8 kΩ		
Range in clear field of vision	up to 70 m		

	the t.bone freeU PT 600 (item no. 405082)	the t.bone freeU PT 823 (item no. 405080)	the t.bone freeU PT 863 (item no. 405084)
Number of channels	100 (10 pre-programmed frequency groups, each with 10 channels available)	100 (10 pre-programmed frequency groups, each with 10 channels available)	16 (4 pre-programmed frequency groups, each with 4 channels available)
Max. number of parallel systems	6-8	3-4	3
Modulation type	Frequency modulation (FM)		
Peak deviation	± 48 kHz		
Power supply	2 × AA cells (LR06, 1.5 V) or corresponding rechargeable batteries		
Operating time	> 10 h (with alkaline cells)		
Dimensions (W × H × D, without antennas)	63 mm × 110 mm × 21 mm		
Weight (without batteries)	90 g		
Ambient conditions	Temperature range	0 °C...40 °C	
	Relative humidity	20 %...80 % (non-condensing)	

Further information

	the t.bone freeU PT 600 (item no. 405082)	the t.bone freeU PT 823 (item no. 405080)	the t.bone freeU PT 863 (item no. 405084)
Max. number of radio links	6-8	3-4	3

8 Plug and connection assignment

Introduction

This chapter will help you select the right cables and plugs to connect your valuable equipment in such a way that a perfect sound experience is ensured.

Please note these advices, because especially in 'Sound & Light' caution is indicated: Even if a plug fits into the socket, an incorrect connection may result in a destroyed power amp, a short circuit or 'just' in poor transmission quality!

Balanced and unbalanced transmission

Unbalanced transmission is mainly used in semi-professional environment and in hifi use. Instrument cables with two conductors (one core plus shielding) are typical representatives of the unbalanced transmission. One conductor is ground and shielding while the signal is transmitted through the core.

Unbalanced transmission is susceptible to electromagnetic interference, especially at low levels, such as microphone signals and when using long cables.

In a professional environment, therefore, the balanced transmission is preferred, because this enables an undisturbed transmission of signals over long distances. In addition to the conductors 'Ground' and 'Signal', in a balanced transmission a second core is added. This also transfers the signal, but phase-shifted by 180°.

Since the interference affects both cores equally, by subtracting the phase-shifted signals, the interfering signal is completely neutralized. The result is a pure signal without any noise interference.

1/4" TS phone plug (mono, unbalanced)



1	Signal
2	Ground, shielding

1/4" TRS phone plug (mono, balanced)



1	Signal (in phase, +)
2	Signal (out of phase, -)
3	Ground

XLR plug (balanced)

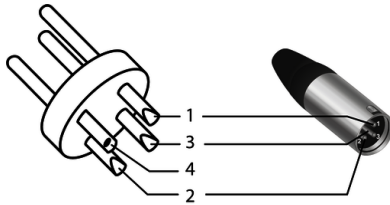

1	Ground, shielding
2	Signal (in phase, +)
3	Signal (out of phase, -)
4	Shielding on plug housing (option)

Mini XLR



1	Ground
2	Positive signal (+)
3	Negative signal (-)

9 Troubleshooting

In the following we list a few common problems that may occur during operation. We give you some suggestions for easy troubleshooting:

Symptom	Remedy
No sound	<ol style="list-style-type: none"> 1. Check the power supply of transmitter and receiver. 2. Make sure that transmitter and receiver are operating in the same frequency range. The frequency range can be found on the devices. 3. Are transmitter and receiver set to the same channel? 4. Test the connection between the receiver and the connected audio device (amplifier, mixer). Is the connected audio device turned on and does the signal level at the output of the receiver match the input requirements of the audio device? 5. See if the audio transmission works when you move the transmitter closer to the receiver. 6. Make sure that no metal objects near the transmitter or receiver obstruct the transmission.
Transmission is interrupted.	<ol style="list-style-type: none"> 1. Modify the orientation of the antennas.

Symptom	Remedy
	2. If you use more than one wireless system at the same time, check the used frequencies and channels.
	3. Interference can also be caused by other radio or in-ear systems.

If the procedures recommended above do not succeed, please contact our Service Center. You can find the contact information at www.thomann.de.

10 Protecting the environment

Disposal of the packaging material



For the transport and protective packaging, environmentally friendly materials have been chosen that can be supplied to normal recycling.

Ensure that plastic bags, packaging, etc. are properly disposed of.

Do not just dispose these materials with your normal household waste, but make sure that they are fed to a recovery. Please follow the notes and markings on the packaging.

Disposal of batteries



Batteries must not be disposed of as domestic waste or thrown into fire. Dispose of the batteries according to national or local regulations regarding hazardous waste. To protect the environment, dispose of empty batteries at your retail store or at appropriate collection sites.

Disposal of your old device



This product is subject to the European Waste Electrical and Electronic Equipment Directive (WEEE) in its currently valid version. Do not dispose with your normal household waste.

Dispose this device through an approved waste disposal firm or through your local waste facility. When discarding the device, comply with the rules and regulations that apply in your country. If in doubt, consult your local waste disposal facility.

freeU HT, freeU PT



Musikhaus Thomann · Hans-Thomann-Straße 1 · 96138 Burgebrach · Germany · www.thomann.de